

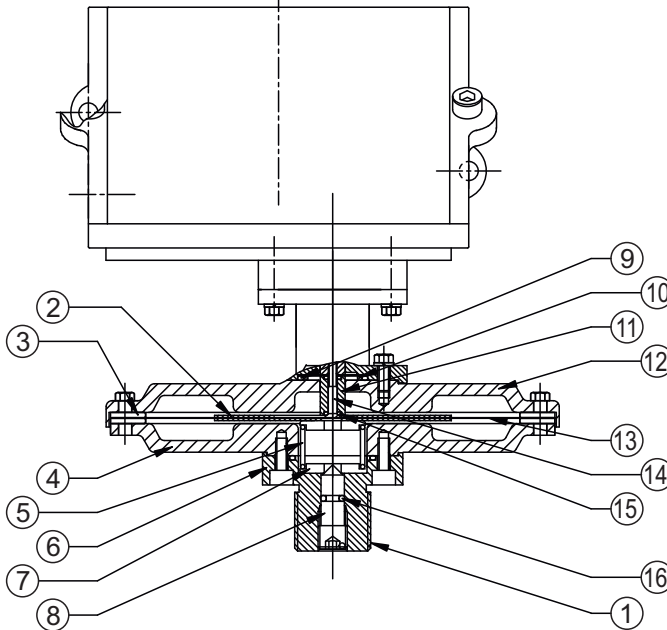

MT



PRESSURE CAPSULE DETAILS



No. Description

1. Pressure Port (SS)*
2. Support Plate (SS)
3. Gasket (PTFE®)
4. Bottom Flange (SS)
5. Support Spring (SS)
6. Mounting Adaptor (SS)
7. Spring Support (SS)
8. Spring Locating Pin (SS)
9. Sealing Ring (Neoprene)
10. Support Ring (CS)
11. Transfer Pin (SS)
12. Top Flange (Viton)
13. Diaphragm (Neoprene)
14. Clamping Screw (CS)
15. O-Ring (Viton)
16. O-Ring (Viton)

Note : *wetted parts* are mentioned in italics.

*Pressure ports are welded with flange

INSTALLATION DRAWING

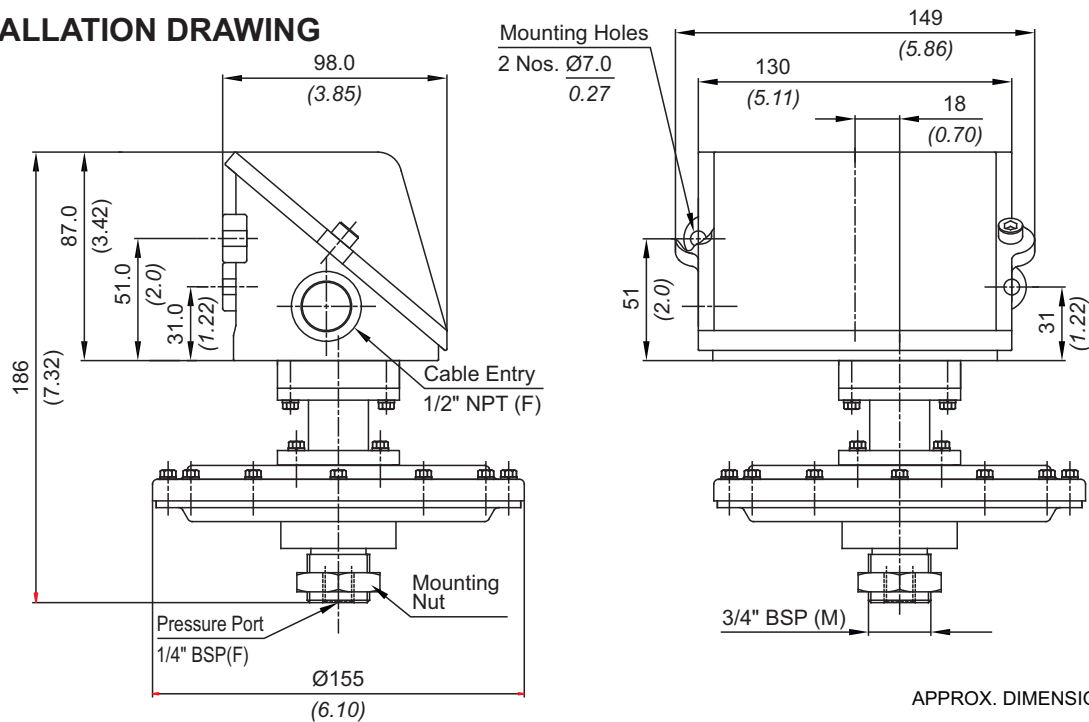

RANGE SELECTION TABLE

Range Code	Range mbar ("Wc)	Differential* mbar ("Wc)	Maximum Working Pressure bar (psi)
		Approximate Maximum for "A1" microswitch	
U15	0.6 - 1.5 (0.24 - 0.6)	0.50 (0.20)	0.5 (7.25)
U25	0.8 - 2.5 (0.32 - 1.0)	0.80 (0.32)	0.5 (7.25)
U40	1.0 - 4.0 (0.40 - 1.6)	1.20 (0.48)	0.5 (7.25)

Note:

1. The minimum differential increases with the setpoint. The differential values mentioned in the above table are approximate maximum for FSR. The differential value will vary according to the pressure range selected and microswitch type. For actual values of differential please contact sales office.

2. When using 2SPDT switching arrangement, both microswitches may not actuate and/or deactuate at the same point. A small stage gap, normally upto +/- 5% FSR (depending on range code) may be observed. The On-Off differential (hysteresis) typically tends to be atleast double of those published for 1SPDT pressure switches.

If actuation and/or deactuation at same point is critical part of operation, then it can be achieved by using a separate DPDT relay. This relay will need a separate power supply for it's coil.

HOW TO ORDER INDUSTRIAL ULTRA LOW RANGE PRESSURE SWITCHES

ULTRA LOW RANGE PRESSURE SWITCHES

MD/MT

Group 1	Group 2	Group 3	Group 4	Group 5	Group 6	Group 7	Group 8									
Non standard allocation	Model	Cable Entry Size	Switch Type	Range Code (values in mbar)	Microswitch Type	Pressure Port Material / Size	Diaphragm									
<input type="checkbox"/> A prefix "N" is used in the model code in case of any non standard options / accessories that are provided with the switches. Will be given by manufacturer, only after agreement of supply details with customer.	MD = Industrial pressure switch with IP66 rated enclosure as per IS/IEC 60529 MT = Industrial pressure switch with IP66 rated enclosure as per IS/IEC 60529	1 = Al. enclosure 1/2" NPT threads *2 = Al. enclosure 3/4" NPT threads 3 = Al. enclosure M20 X 1.5 threads 7 = SS enclosure, 1/2" NPT threads *8 = SS enclosure, 3/4" NPT threads 9 = SS enclosure, M20 X 1.5 threads	PF2 = pressure switch, fixed differential with scale in mbar PF3 = pressure switch, fixed differential with scale in "Wc *PA2 = pressure switch, adjustable differential with scale in mbar *PA3 = pressure switch, adjustable differential with scale in "Wc	U15 = (0.6 - 1.5) U25 = (0.8 - 2.5) U40 = (1.0 - 4.0)	A1 = General purpose microswitch, rated at 15 A; 250 VAC *A6 = Adjustable deadband *A7 = 2SPDT switching elements *A8 = General purpose microswitch *B7 = 2SPDT Switching Elements	S1 = SS316 / 1/4" BSP(F) S2 = SS316 / 1/4" NPT(F)	0 = Neoprene 1 = PTFE									
The prefix is subject to change as per specific requirement.		*Not available for MT model For dual cable entry contact Sales Office	*Available with A6, A7, A9 & B9 (in group 6) only		* Please refer to page nos. 290 & 291 for options and specifications of microswitches Please contact sales office for additional information	More options available, please contact sales office										
Approx. switch weight in Kgs																
<table border="1"> <thead> <tr> <th>Enclosure</th> <th>MD</th> <th>MT</th> </tr> </thead> <tbody> <tr> <td>Aluminium</td> <td>3.190</td> <td>3.560</td> </tr> <tr> <td>SS</td> <td>4.700</td> <td>5.155</td> </tr> </tbody> </table>								Enclosure	MD	MT	Aluminium	3.190	3.560	SS	4.700	5.155
Enclosure	MD	MT														
Aluminium	3.190	3.560														
SS	4.700	5.155														

eg. Industrial pressure switch with 1/2" NPT cable entry in aluminium housing as 1SPDT pressure switch, fixed differential with scale in mbar, having 0.16 to 0.60 "Wc pressure range, with 15Amp. microswitch, SS316 pressure housing with 1/4" BSP port size & neoprene diaphragm shall be specified by

Group 1	Group 2	Group 3	Group 4	Group 5	Group 6	Group 7	Group 8
<input type="checkbox"/>	MD	1	PF2	U15	A1	S1	0

Please specify full model number to avoid ambiguity.